

自由者 2300

freeman2300

用户手册 v1.0

User ManualV1.0

2019.05

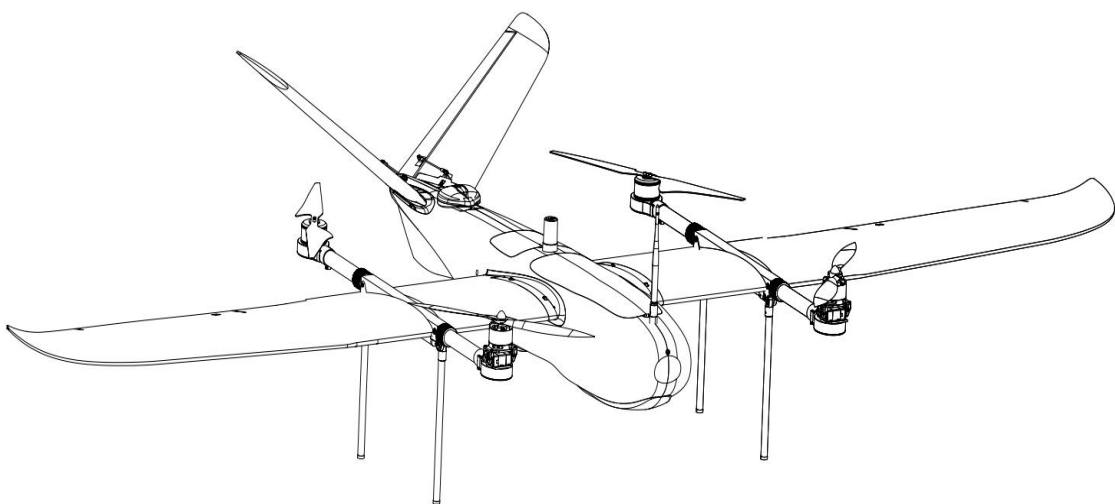

mfe
makeflyeasy

产品概述

简介 Introduction

自由者 2300 是一款倾转式垂直起降固定翼飞行平台，具有携带易用，操作友好，稳定耐用等特点。自由者 2300 定位为一款高性价比的入门级倾斜摄影固定翼，让更多航测用户入门倾斜摄影，在真实的三维的空间探索数据的应用价值。

模块化设计理念让飞机组装工作简单快捷，可快拆机翼、可折叠机臂，可快拆尾翼、使飞机具有实用的便携性和友好的用户体验。独立的飞控舱支持常见的倾转式垂直起降固定翼飞控，推荐挂载 5 个减重版本的索尼 A5100 相机 (约 900g)，搭配 6S@22000mah 锂聚合物电池，可以实现 60KM 的续航和高质量的倾斜拍摄效果。

配合适量控制点成图结果满足 1:500、1:1000 和 1:2000 航测标准，三维模型可应用于地形测绘、农林牧防护、电力巡线、环保、水利等方面。

Freeman 2300 is a fixed-wing design aircraft which is tilting type and vertical take-off and landing. It is characterized by many advantages such as portability, simplicity, stability and durability. Freeman2300 is an oblique photograph aircraft, which market positioning is high cost perform and entry-level. And aim to help more clients to getting start with oblique photograph, exploring the application value of data in three-dimensional space.

Thanks for the Modular design of whole aircraft; it's very convenient to conduct the assembly during outside aerial photogrammetric field operation. Quick release wings, empennage and foldable arms provide excellent using experience for our customers. Separate flight control module could support the common vertical take-off and landing flying control. We recommend mount 5pcs light-weight version Sony A5100 camera (about 900g), and concomitant with 6S@16000mah aluminum polymer battery, which could bring 60km long endurance and high quality shooting effect.

Using proper control point cooperatively, the final mapping would satisfy 1:500, 1:1000 and 1:2000 aerial survey standard, the final model

could realized a wide-ranging application such as geography surveys, farmland, forestry land and grassland protection, power line inspection, environment protection, water conservancy and etc.

产品规格

- 材质：EPO、EVA、碳纤维、工程塑料等
- 翼展：2300mm 机身高：180mm
- 机身长：1070mm 翼面积：62dm²
- 推荐飞行速度：16m/s 失速速度：10m/s
- 最大有效载荷：900g 载荷舱尺寸:120×150×120mm
- 最大航程：60km(900g 负载) 最大起飞重量：8kg
- 实用升限：4000m 抗风能力：5 级
- 起降方式：垂直起降 拆装方式：无工具拆装
- 运输箱寸：1.21m×0.38m×0.44m

Products specifications:

- Material: EPO, EVA, carbon fiber, engineering plastics and etc.
- Wing Span: 2300mm Fuselage height: 180mm
- Fuselage length: 1070mm Wing area: 62dm²
- Suggested flight speed: 16m/s Stalling speed: 10m/s
- Suggested payload: 900g Payload bay size: 120×150×120mm
- Longest flight range: 60km (contain 900g load) Max take-off weight: 8kg
- Practical ceiling height: 4000m Wind resistance: 5
- Take-off and landing approach: vertical Dismounting way: tool-free
- Transport case seize: 1.21mx0.38mx0.44m

产品使用注意事项

安装注意

1. 在焊接大电流连接器时，一定要注意焊接线序要相互对应，以免烧毁电调、舵机。

1. Pay attention to the welding wires sequence which should be corresponding to each other during the welding of large current connector. Or maybe the electric regulator and servo suffered burning-out.

2. 副翼和尾翼推荐使用银燕 **ES3054** 数字舵机，或者其他相同尺寸的舵机及圆盘舵角，便于舵机安装，和尾翼快拆装置的安装。

2. We recommend the EMAX ES3054 digital servo, or other same size servo and round board helm angle for the easy installing of servo and tail wings quick release devices.

3. 起飞重量大于 7.5kg 情况，需要用户自己加强机翼和尾翼。

3. Stiffening the wings and empennages when the take-off weight was more than 7.5kg.

4. 在安装电机座时注意调至水平。

4. Please adjust the front and rear motor frame to the level during installation.

5. 自由者电源供电方案请参考下图。

5. Please refer to below the Freeman power supply conceptual drawing when you were confused by the Installing sequence.

自由者供电方案图 Freeman power supply conceptual drawing

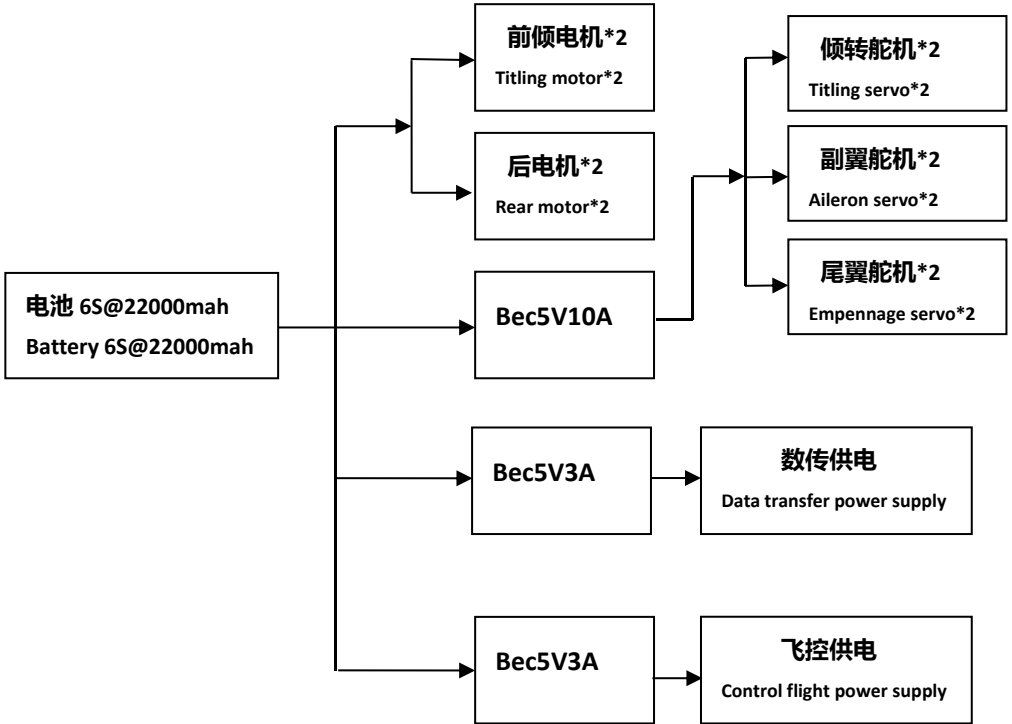

飞行注意 Flying Attentions

1. 请避免在 12m/s 以下的速度飞行转弯，以免飞机失速。
1. Don't cornering when the aircraft flying speed was less than 12m/s, or the aircraft maybe stalling.
2. 飞行前请务必检查电机、螺旋桨安装正确稳固，电调信号线和电源线插头连接坚固可靠。
2. Ensure the motor and propeller were installed correctly and toughly before flying, inspecting the electronic regulating signal wires and power lines plug, ensure they were connected toughly.
3. 飞行时请远离不安全因数，如障碍物、人群、儿童、建筑物、高压线等。
3. Away from the unsafe factors such as barrier, crowd, children, buildings, high-voltage wires and etc while flying.
4. 务必在安全起飞重量下飞行，切勿在机场净空区范围飞行。
4. Takeoff under the safety weight and never flying in the area of airfield clearance zone.
5. 请按标识重心位置配重（位于机翼翼根塑料件下突起处沿尾翼方向移动 15mm）。
5. Conduct the counterweight at the marked center of gravity position. (At the protrusion which was under the plastic parts of wings root and moved towards wings tail 15mm.)

盒内物品清单 Contents in the box

EPO 部件 EPO Parts

1 左右机翼 1 left & right wing

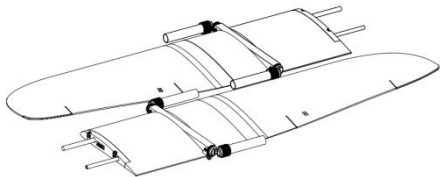

2 左右尾翼 2 left & right empennage

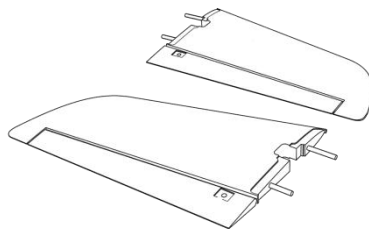

3 左右机身 2 left & right fuselage

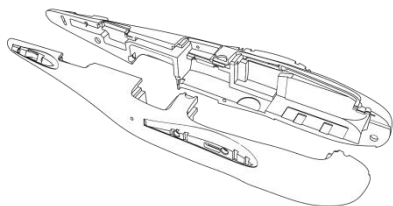

5 机舱盖 5 Cabin cover

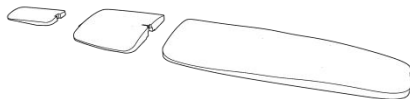

6 伞舱盖 6 Parachute cabin cover

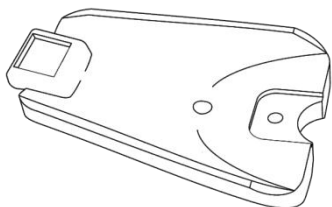

7 腹鳍 7 Ventral fin

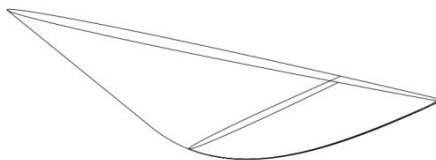

碳管部件 Carbon tube parts

1 机身支撑碳管

1 Fuselage supporting carbon tube
14*12*206mm
12*10*206mm



2 折叠起落架

2 Foldable landing gear



金属及碳片部件

1 电机座*4

1 Motor frame

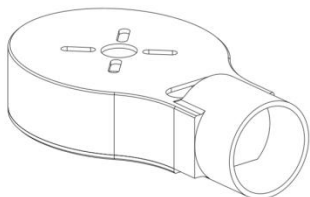

2 电机盖片

2. Motor cover plate

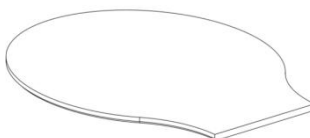

3 金属锁钩*8

3 Mental latching hook*8

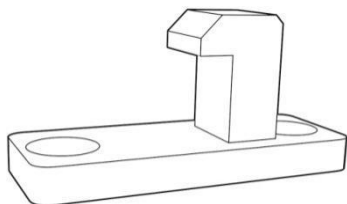

4. 负载挂架

4 Load mounting

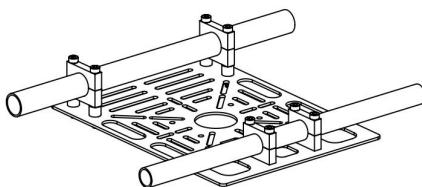

塑料件 Plastic parts

1 机翼连接件*2

1 Wings connecting parts*2

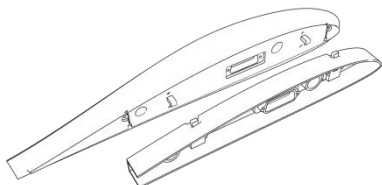

2 尾翼连接件*2

2 Empennages connecting parts*2

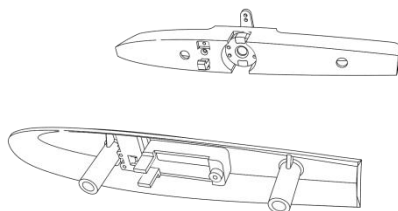

3 舵机固定件*2

3 Servo fixing parts*2

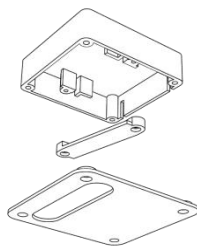

舵机安装座

servo installing base

舵机压片

servo presser

舵机盖板

servo covering plate

4 舵角*4

4 Helm angle *4

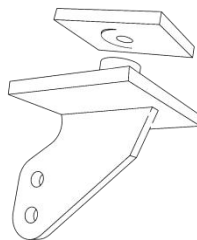

5 电池固定板*1

5 Battery fixing board*1

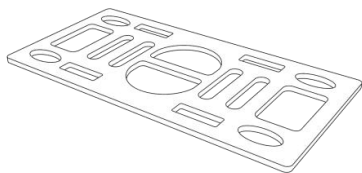

6 天线固定板*2

6 Antenna fixing board*2

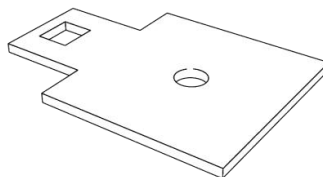

7 舱盖固定板*1
7 Cabin cover fixing board*1

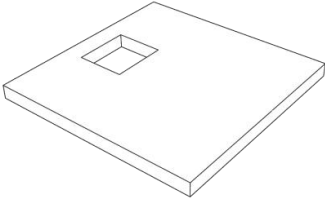

8 螺丝柱*12
8 Stud*12

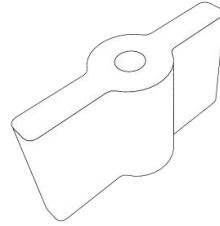

9 舱盖锁钉*4
9 Cabin cover locking nail*4

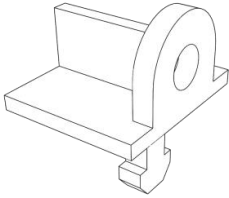

10 卡盘*2
10 Chuck*2



木板部件 Wooden parts

1 机身加强层板*2
1 Fuselage reinforcing plate*2

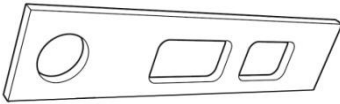

2 机尾加强层板
2 Tail reinforcing plate

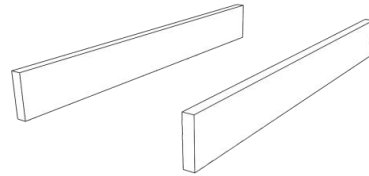

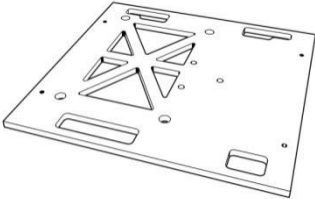
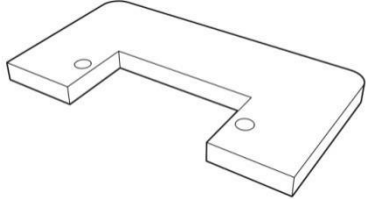
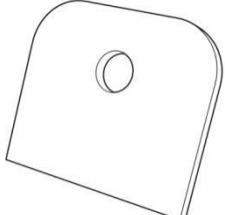
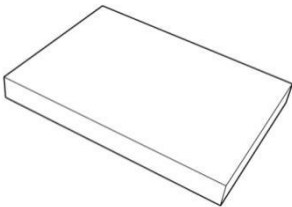
<p>3 飞控放置板*1 3 Autopilot locating board*1</p> 	<p>4 伞舱舵机座*1 4 Basement of parachute servo*1</p> 
<p>5 伞舱盖木板*1 5 Wooden plate of parachute hatch cover*1</p> 	<p>6 伞舱盖加强板*1 6 Stiffer of parachute hatch cover *1</p> 

EVA 部件 (电池区缓冲垫、飞控区缓冲垫)

EVA parts (Cushion at battery area, cushion at flight control area)

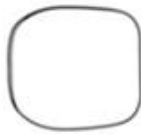
<p>1 电池区缓冲垫 1 Cushion at battery area</p> 	<p>2 飞控区缓冲垫 2 Cushion at flight control area</p> 
---	--

其他配件 Other fittings

序号 NO.	名称及型号 Name & Model	数量 Qty	备注 Notes
1	大电流连接器 Large electronic current connector	2 套 2 groups	
2	尾翼舵机延长线 30cm Empennage servo extending wire 30cm	2 根 2 sets	
	机身信号三端母头延长线 35cm Fuselage signal extending wire with three-terminal 35cm	2 根 2 sets	机身部分 fuselage section
	机身舵机电源信号延长线 35cm Fuselage and servo signal extending wire 35cm	2 根 2 sets	机身部分 fuselage section
	舵机线 (60 芯) Servo wire (60 core)	2 米 2m	机翼部分 wing section
3	14AWG 硅胶线 (黑) 14AWG Silicone wire (black)	2 米 2 m	
	14AWG 硅胶线 (红) 14AWG Silicone wire (red)	2 米 2 m	
4	热缩管直径 2.5mm*15mm Diameter of heat shrink tubing 2.5mm*15mm	30 段 30 sections	
	热缩管直径 6mm*15mm Diameter of heat shrink tubing 6mm*15mm	12 段 12 sections	
5	束线管 Wire harness tube	1 米 1m	
	魔术扎带 Magic tie straps	2 根 2 sets	与电池固定板搭配使用 Matching the battery fixing board
6	透明泡沫胶 Transparent foam glue	2 支 2 PCS	

7	球头 Ball head	8 个 8PCS	球头连杆 Ball link rod
	连杆 Link rod	4 根 4 sets	球头连杆 Ball link rod
	圆头螺钉 M2X10 Button head screw M2X10	8 颗 8PCS	球头连杆 Ball link rod
	防松螺母 M2 Block nut M2	8 颗 8 PCS	球头连杆 Ball link rod
8	塑料锁扣 Plastic latch	3 个 3PCS	舱盖锁钉 Hatch cover locking nail
9	断尾圆头螺丝 M2.5X8 Tail button head screw M2.5X8	10 颗 10PCS	大电流连接器、伞舵机 Large electronic current connector, parachute servo
10	断尾圆头螺丝 M2X10 Tail button head screw M2X10	8 颗 8PCS	舵机压片、飞控放置板 Servo presser, autopilot locating board
11	断尾圆头螺丝 M2X8 Tail button head screw M2X8	34 颗 34PCS	机翼舵角、尾翼舵角、金 属锁钩、舵机盖板 Wing helm angle, empennage helm angle, mental latching hook, servo covering plate

辅助安装工具和材料 (自备)

Auxiliary installation tools and materials (Self-contained)

工具 Tools	用途 Usage
3.0mm 十字螺丝刀 3.0 Philips screwdriver	安装螺丝 Installing the screws
内六角螺丝刀 Allen driver	安装电机座 Installing the motor frame
电烙铁、焊锡丝 Electric iron, solder wire	焊接电源、舵机线 Welding the power line and servo line
打火机 Lighter	固定热缩管 Fixed heat shrink tube
小刀 Knife	剥线 Wire stripping tool
纸胶、透明胶、纤维胶带(Transparent) adhesive tape, fabric adhesive tape	飞机粘合辅助定位、飞机局部加强 Aircraft bonding and auxiliary positioning, local reinforce

测试配置与性能 Test configuration & performance

种类 Types	型号 Model	数量 Qty
倾转电机 Tilting motor	朗宇 Sunny sky 3520kv500	2 个 2PCS
后电机 Rear motor	朗宇 Sunny sky 4112kv450	2 个 2PCS
电调 Electronic speed controller	好赢乐天 60A HobbyWing60A	4 个 4PCS
副翼/尾翼舵机	银燕 ES3054	4 个

Aileron/Emppennage servo	EMAX ES3054	4PCS
倾转舵机 Tilting servo	DS3225	2 个 2PCS
前电机桨 Front motor rotor	APC1510 正反桨 APC1510 positive and negative rotor	1 对 1pair
后电机桨 Rear motor rotor	1755 碳纤维正反桨 1755 carbon fiber rotor of positive and negative	1 对 1pair
舵机 BEC Servo BEC	5V@10A	1 个 1PCS
数传 BEC Data transmission BEC	5V@3A	1 个
飞控 Flight control	Pixhawk2.4.6	1 套 1group
动力电池 Power battery	6S@22000mah 锂聚合物 6S@22000mah lithium polymer	1 组 1group
负载重量 Payload weight	5 个减重版 SONY A5100 (900g) 5pcs lighting version of SONY A5100 (900g)	1 台 1set

扫描二维码了解更多 Scan the qr code to learn more



QQ 群
QQ group



淘宝店铺
Taobao store

网址 (URL) : www.makeflyeasy.com

地址 (SITE) : 中国绵阳涪城区西南科大国家大学科技园

SWUST,FuchengDistrict,MianyangCity,Sichuan,CHINA Province, China
National University Science Park